



Application

- Small electrical irrigation and drainage equipments.
- Particularly applied in urban well water pumping, field irrigation and drainage, garden irrigation and household water supply, as well as drainage of industrial accumulated water, water supply and drainage for construction, livestock breeding, etc.

Pump

- Max. immersion depth: 5 m
- Max. liquid temperature: +40°C
- Liquid pH value: 6.5 - 8

Motor

- Built-in thermal protector
- Stainless steel welded shaft
- Insulation class: B
- Protection class: IP68

Identification Codes

XQS 15 - 20 / 1.1 I

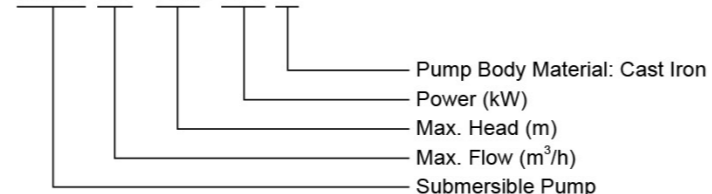

Technical Data

Model	Power		Outlet diameter mm	Max. flow l/min	Max. head m	GW kgs	Packing size mm	Quantity PCS/20' TEU
	kW	HP						
XQS39-8/0.75I	0.75	1	75	650	8	21.6	580x320x250	684
XQS15-20/1.1I	1.1	1.5	40	250	20	21.5	510x290x220	880

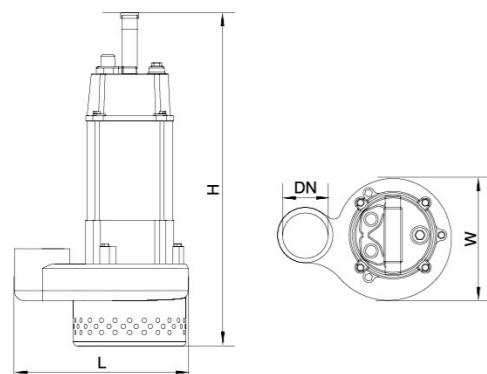

Dimension

Model	DN	L (mm)	W (mm)	H (mm)
XQS39-8/0.75I	2 1/2"	207	109	500
XQS15-20/1.1I	1 1/4"	238	177	460

Hydraulic Performance Curves

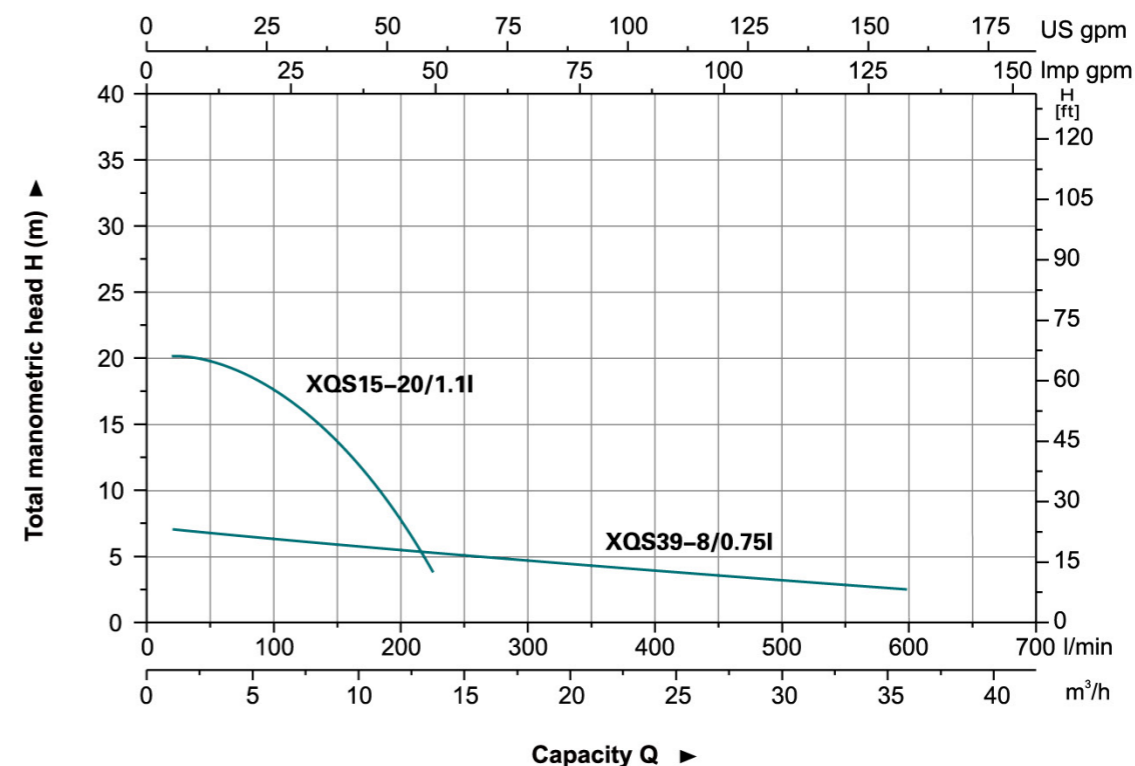

Materials Table

No.	Part	Material	No.	Part	Material
1	Bolt	Stainless steel	26	Thermal protector	
2	Stretching washer	Stainless steel	27	O-ring	NBR
3	Washer	Stainless steel	28	Stator	
4	Bolt	Stainless steel	29	Wave washer	65Mn
5	Washer	Stainless steel	30	Ball bearing	
6	Handle	Stainless steel	31	Rotor	
7	Nut	Stainless steel	32	Ball bearing	
8	Protector	NBR	33	Lower cover	HT200
9	Cable presser	Stainless steel	34	Oil seal	
10	Washer	Stainless steel	35	Connector	ABS
11	Screw	Stainless steel	36	O-ring	NBR
12	Bolt	Stainless steel	37	Pump body	HT200
13	O-ring	NBR	38	Mechanical seal	Ceramic/Carbon
14	Screw	Stainless steel	39	Impeller	HT200
15	Flange	Stainless steel	40	Nut	Stainless steel
16	Cable		41	O-ring	NBR
17	Cable protector	CR	42	Pump body	HT200
18	Capacitor cover	HT200	43	Washer	Stainless steel
19	Capacitor		44	Screw	Stainless steel
20	O-ring	NBR	45	Filter mesh	Steel
21	Cable holder	NBR	46	Washer	Stainless steel
22	Screw	CuZn40	47	Screw	Stainless steel
23	Stretching washer	65Mn	48	Stretching washer	Stainless steel
24	Washer	CuZn40	49	Float switch	
25	Upper cover	HT200			

